

**OPTIM 2-M: Two steps, single phase Power Factor correction equipment**

This is the installation guide for the power factor correction equipment OPTIM 2-M. The guide can be downloaded from our website [www.circutor.es](http://www.circutor.es)

**WARNING!**  
Improper connection of the equipment can result in death, serious injury, or fire hazard. All work involving the equipment should be performed by qualified personnel according to Local National Electrical Code regulations and in compliance with all applicable safety standards. If the equipment is used in a manner not specified by the manufacturer, its protection may be compromised. Before performing any installation, repair or replacement of parts of the equipment, disconnect it from the power supply. When you suspect a malfunction of the equipment contact the CIRCUTOR technical service.

**1 DESCRIPTION**

The **OPTIM 2-M** are single phase power factor (PF) compensation equipment with two capacitor steps. They are operated by a **Computer two m** PF controller relay. They consist of two groups with one or two cylindrical capacitors model CLM, operated by a three phase contactor and protected by a bipolar circuit breaker (MCB).



The PF control is performed by a **Computer two m** controller relay. The reactive power consumption is measured by means of the signal from a current transformer (CT) inserted in one of the cables supplying the installation. Proper CT secondary terminals (see section 2.6) must be connected to terminals S1 and S2 inside the equipment.

All switching elements are mounted inside a housing enclosure made of thermoplastic material.

**2 INSTALATION AND START UP**
**2.1 Delivery checking**

Make sure that the equipment matches the specifications of your order and that it is delivered without suffering any damage.

**2.2 Current transformer (CT)**

The operation of this equipment requires an external current transformer (CT) measuring the load current. The suitable type of CT is a xx/0,25A, (i.e. a transformer of CIRCUTOR

MC1 series, with rated secondary current of 0,25A ). **xx** is the nominal primary current, which should be adequate for the maximum current drawn by the total of the loads to be compensated.

**2.3 Equipment location**

The equipment must be placed indoor, away enough from heat sources and in an adequately ventilated place. Attach the equipment on a wall panel by means of suitable screws, passing through the holes in the rear wall of the enclosure.

**2.4 Initial checking (before connecting the supply)**

- Check that the rated voltage of the device, given at the label, matches the voltage of the network to which to connect it.

- Remove the cover of the cabinet, removing the fixing screws and disconnect the MCB (from position I to position O).

**2.5 Power circuit connection**

- Connect the two power terminals (L1, N) to the supply network, using the appropriate cable size (see current at the equipment's label). Use the cable entry holes provided in the top to introduce the cables into the enclosure. The suitable cable size must be determined according to Electrical national Code. As a guide, IEC recommendations specify that the cables and protective devices for PF correction equipment, involving capacitor loads must withstand permanently at least 1.5 times the rated current of the capacitor equipment.

**2.6 Measuring and control circuit connections**

- Install the current transformer (CT) at a point where it measures the whole load current plus the PF correction equipment current (Supply side from the point of connection of PF correction equipment). See the connection diagram (section 5).

**Observe the polarity of the current transformer (current sense P1 to P2).**

**The transformer must be inserted at the phase connected to L1 terminal.**

- Connect the secondary side of current transformer (CT) to terminals S1 and S2, inside the equipment. Secondary side of xx/0,25A CT has an output common terminal 1S1. The other terminal, 1S2, 2S1 or 2S2, depends on the desired nominal primary current (see label of type MC1 TC). The connection to S1 and S2 must be done using at least 1.5 mm<sup>2</sup> cables. In order to get an adequate measuring accuracy, it is important to properly select the nominal value of the primary current of CT. The value must be slightly above (maximum twice) the maximum load current.



Note that the terminals and other internal conductive parts of the equipment are potentially dangerous when equipment is connected to the supply voltage, therefore, the contact with them involves a risk of electrocution. The equipment should not be used until its installation is completely finished. The equipment's auxiliary power supply must be protected with fuses or a circuit breaker (CB), with a size according to the equipment power consumption. CIRCUTOR recommends the use of a CB or equivalent device, allowing the disconnection of the equipment from the mains..

**3 COMPUTER TWO M SETUP (C/K)**

The value of C/K to adjust the **Computer two m** has a special calculation formula given below.

$$C / K_{TWO\_M} = \frac{I_c}{I_p / 5}$$

$I_c$  = Capacitor current (at 230V can be calculated as  $kvar * 1000 / 230$ )

$I_p$  = CT primary current (see TC label).

In order to compensate when power consumption is low, we advise to set the C/K at 90 % of the calculated value.

**Example:**

Equipment: OPTIM 2-M-5-230 (2,5 + 2,5kvar)  
Assume a CT with a ratio 50/0,25 A  
 $I_c$  for 2,5kvar at 230V is 10,9A  
Theoretical C/K:  $10,9 A / (50/5) = 1,09$   
Recommended adjustment: 0,9 to 1,09

Once the  $C/K_{TWO\_M}$  has been adjusted, check that the contactor switches ON with a low load consumption. If not, set the  $C/K_{TWO\_M}$  to a lower value, until the contactor connects with 10% - 20% of the load

**4 COMPUTER TWO-M SIGNALING LEDES**

- **Green LED CPU:**  
*Computer one m* is connected to supply
- **Red LEDES RELAY:**  
Indicates that the internal relay is ON, so contactor should be ON
- **Red LEDES ALARM 1 & 2:** Indicate that there is an alarm. See alarms table to identify the problem

## 5 CONNECTIONS SCHEMATIC

**IMPORTANT! MAKE SURE THAT THE CURRENT TRANSFORMER (CT) IS PLACED AT THE SUPPLY SIDE FROM THE POINT OF CONNECTION OF PF CORRECTION EQUIPMENT**

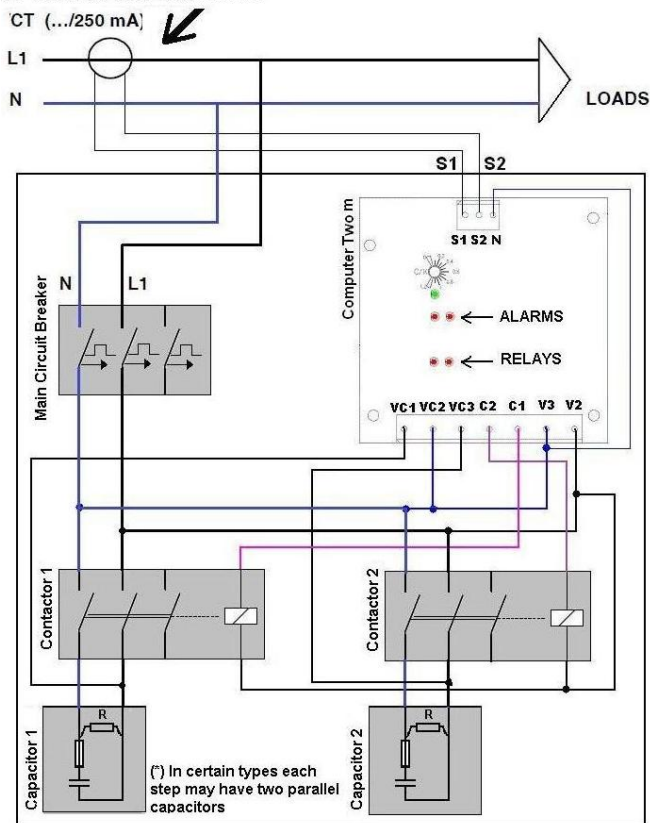

## 6 ALARMS TABLE

○ LED OFF ● LED ON ◐ Blinking LED

ALARM CODE	Description (in priority order)
1 ● 2 ●	<b>Low current:</b> Sensed current below minimum threshold. May be CT not connected). The alarm threshold is activated when secondary current of CT is below 10 mA.
1 ○ 2 ◐	<b>Temperature.</b> The controller has measured 65°C during 30minutes or more than 75°C during more than 10 seconds . <b>The reset of this alarm is automatic when the temperature falls below 55°C,</b> nevertheless LED 2 keeps blinking at very low cadence when an alarm has occurred.
1 ● 2 ◐	<b>Erroneous connection.</b> The PF controller measures a $\cos\phi$ out of the range considered normal (0,4 inductive to 0,98 capacitive). Review the connection according to schematic. (mainly review cables to terminals V2, V3, S1 and S2).
1 ◐ 2 ●	<b>Operation error.</b> The controller is measuring a $\cos\phi$ less than 0,95 inductive and the contactor is not connecting, Review the adjustment of C/K and connection to contactor.
1 ◐ 2 ○	<b>Lack of voltage at C terminals.</b> Although the controller is ordering the relay closure, it doesn't detect any voltage across the capacitor. Review the connections according to schematic.
1 ○ 2 ●	<b>Overcurrent:</b> .The controller measures a current above the maximum ( 0,25 A + 15 %)
1 ● 2 ○	<b>Overvoltage.</b> The controller is measuring a voltage above 230 V + 15 %

## 7 TECHNICAL CHARACTERISTICS

Supply and measurement circuits	
Rated Voltage	Single phase 230 Vac
Tolerance	±10%
Frequency	50 Hz ± 10%
Rated power	See label
Residual voltage	≤ 75 V after 3 minutes
Overload capacity	1,3 I <sub>n</sub> all the devices
Rated current input	0,25 A (Current transformer I <sub>n</sub> /250 mA)
Contactors control voltage	230 Vac

Ambient conditions		
Temperature	Minimum	-10°C
	Maximum during 1 h:	50 °C
	Average 24 h:	40 °C
	Year average :	30 °C
Maximum relative humidity	85% , without condensation	
Maximum altitude	1000 m	
Protection degree	IP 20	

Mechanical characteristics	
Housing material	Thermoplastic Grey , RAL 7035
Dimensions	215 x 500 x 166 mm

Standards	
UNE-EN 61921:2004, UNE-EN 60831:2012	

## 8 DIMENSIONS

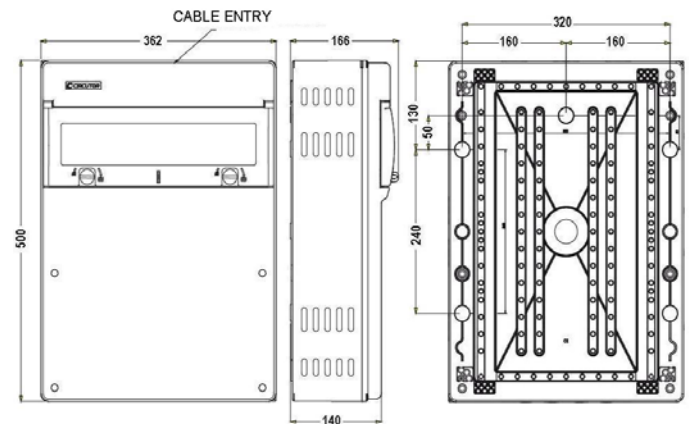

## 9 MAINTENANCE AND TECHNICAL SERVICE

In the event of questions or concerns regarding operation or malfunction of the equipment, notify Technical Assistance Service (SAT) of CIRCUTOR, SA.

Vial Sant Jordi, s/n –

08232 – Viladecavalls

Barcelona – Spain

Tel: 902 449 459 ( Spain ) / +34 937 452 900 (International)

e-mail: sat@circutor.es

Web: www.circutor.es